

3M™ Water Filtration Products

SPEC# _____

QUANTITY _____

application: **COOLER FILTRATION**

models:

CMTRO-75



New! Cooler RO

- 23.59 Gallon per day (107.2 Liter per day) Capacity
- Reduces¹:

- Arsenic	- Barium
- Cadmium	- Chromium
- Copper	- Fluoride
- Lead	- Radium 226/228
- Selenium	- Cyst ²
- Chlorine Taste and Odor	

¹ See PDS for more Details

² Tested per NSF/ANSI Standard 58

PRODUCT BENEFITS

- Compact design for use in point of use coolers.
- Sanitary quick change (SQC) system eliminates the need to handle filter media.
- Easy to change filters -- Just a quarter turn!
- 23.59 gpd RO Membrane
- NSF 58 Certified
- NSF 42 Certified
- 10 Year System Warranty

PRODUCT SPECIFICATIONS

Model Number	Part Number	Description	Connections	Cartridge Description	Cartridge Number
CMTRO-75	05-735	Cooler RO 23.59 GPD 2 Gallon Tank Included	1/4" NPT Input	Prefilter	47-55706G2
			3/8" NPT Output	Post Filter	47-55710G2
				RO Membrane	66-4710G2



CMTRO-75

SPEC# _____
 QUANTITY _____
 MODEL NUMBER _____
 PART NUMBER _____

3M™ Water Filtration Products

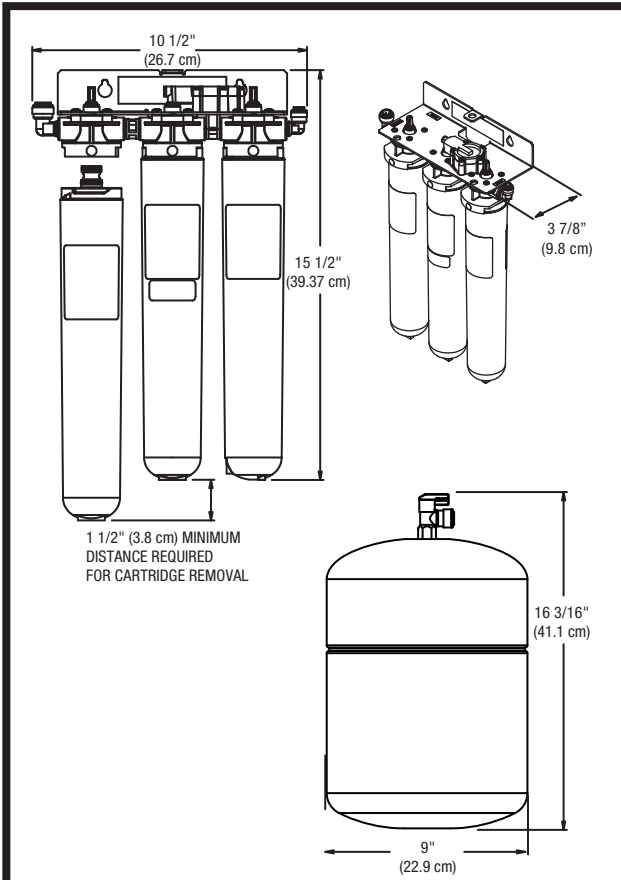

⚠ WARNING: To reduce the risk associated with the ingestion of contaminants:

• Do not use with water that is microbiologically unsafe or of unknown quality without adequate disinfection before or after the system. Systems certified for cyst reduction may be used on disinfected water that may contain filterable cysts. EPA Establishment #070595-CT-001

CUNO Incorporated recommends regularly scheduled maintenance and replacement of the filter cartridge in order for the product to perform as advertised/sold. CUNO shall not be liable for system failures due to improper maintenance.

LIMITED WARRANTY

CUNO Incorporated warrants this Product (excluding disposable filter cartridge) to be free from defects in material and workmanship for ten (10) years from the date of purchase. The disposable filter cartridges are warranted from defects in material and workmanship for a period of eighteen (18) months from the date of purchase. This warranty does not cover failures resulting from abuse, misuse, alteration or damage not caused by CUNO or failure to follow installation and use instructions. If the Product is defective CUNO will replace the Product or refund your Product purchase price. CUNO will not be liable for any indirect, special, incidental, or consequential damages arising from the use of this Product. Some states do not allow the exclusion or limitation of incidental or consequential damages, so the above limitation may not apply to you. To obtain warranty service, mail your request to Warranty Claims, CUNO Incorporated, 400 Research Parkway, Meriden, CT 06450. Proof of purchase (original sales receipt) must accompany the warranty claim, along with a complete description of the Product, model number and alleged defect. This warranty gives you specific legal rights and you may have other rights which vary from state to state, or country to country.

PHYSICAL SPECIFICATIONS

- Includes head bracket with mounting bracket and mounting screws.
- 1/4" Inlet and 3/8" outlet connections.
- System maximum operating pressure of 100 psi (690 kPa) and operating temperature of 100°F (37.8°C).
- 23.59 Gallon per day (107.2 Liter per day)

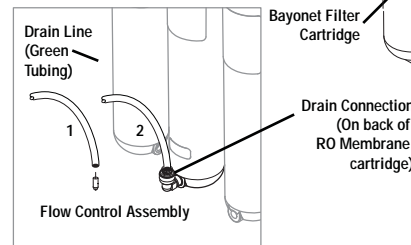
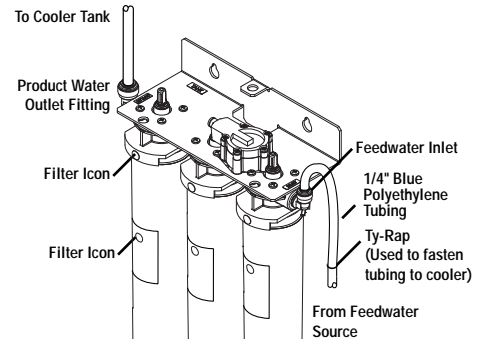

IMPORTANT: INSTALLATION TIPS

These installation tips are for informational purposes only and are not intended to be used as actual installation instructions. **CAUTION: To reduce the risk associated with property damage due to water leakage:**

- **Read and follow** Use Instructions before installation and use of this system.
- Installation and use **MUST** comply with all state and local plumbing codes.
- **Protect from freezing**, remove filter cartridge when temperatures are expected to drop below 40°F (4.4°C).
- **Do not install on hot water supply lines.** The maximum operating water temperature of this filter system is 100°F (37.8°C).
- **Do not install** if water pressure exceeds 100 psi (689 kPa). If your water pressure exceeds 80 psi (552 kPa), you must install a pressure limiting valve. Contact a plumbing professional if you are uncertain how to check your water pressure.
- **Do not install** where water hammer conditions may occur. If water hammer conditions exist you must install a water hammer arrester. Contact a plumbing professional if you are uncertain how to check for this condition.
- The disposable filter cartridge **MUST** be replaced every 18 months, at the rated capacity or if a noticeable reduction in flow rate occurs.
- The disposable membrane **MUST** be replaced every 18-36 months, at the rated capacity or if a noticeable reduction in flow rate occurs.



Tested and certified by NSF International against NSF/ANSI Standards 42 and 58 for reduction of claims specified on the Performance Data Sheet.

3M is a trademark of 3M Company.
 NSF is a trademark of NSF International.
 © 2009 3M Company. All rights reserved.
 Not for use in residential applications in the states of CA or WI. Not for sale in Iowa.
 70-0202-5056-2
 REV 1209



CUNO Incorporated
 a 3M Company
 400 Research Parkway
 Meriden, CT 06450 U.S.A.
 Toll Free: 1.888.218.CUNO
 Worldwide: 203.237.5541
 Fax: 203.238.8701
 www.cuno.com